

**MITSUBISHI ELECTRIC
HYDRONICS & IT COOLING SYSTEMS S.p.A.**

IT COOLING

CHILLERS

TRCS2 HFO-Z

**AIR AND WATER COOLED CHILLERS WITH MAGNETIC
LEVITATION COMPRESSORS AND HFO 1234ZE
REFRIGERANT, FROM 339 KW TO 1364 kW**

GREEN  **EFFICIENCY**



“The ultimate objective of this Convention is to achieve stabilization of greenhouse gas concentrations in the atmosphere at a level that would prevent dangerous anthropogenic interference with the climate system. Such a level should be achieved with a time frame sufficient to allow ecosystems to adapt naturally to climate change, to ensure that food production is not threatened and to enable economic development to proceed in a sustainable manner.”



United Nations
Framework Convention on Climate Change
UNFCCC, 1992

THE CALL FOR CLIMATE ACTION

Tackling stratospheric ozone depletion and the greenhouse effect have led to drastic regulatory changes in the HVAC&R industry. Starting from the United Nations Framework Convention on Climate Change UNFCCC, the Member States are progressively setting more challenging targets in order to:

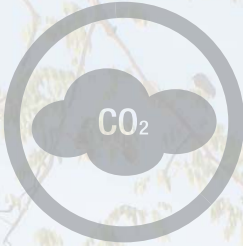

Reduce greenhouse gas emissions (GHG)

Reduction in greenhouse gases and -40% of CO₂ emissions by 2030



Tackle climate change

Keep global warming within 2°C compared to pre-industrial era (1850)



Promote sustainable development

Increase use of renewables and efficiency targets for energy related products

This has posed new challenges for the HVAC industry:

Against Global Warming



Refrigerant greenhouse and global warming potential are measured by two parameters:

- ▶ **ODP** Ozone Depletion Potential
- ▶ **GWP** Global Warming Potential

While in the past the main focus was on reducing ODP values down to 0, new regulations now encourage Member States to work harder on GWP.

Challenging efficiency targets



Countries are becoming more and more aware that environmental targets must be regulated by laws and programs in terms of energy efficiency targets related both to products:

- ▶ **ERP** Ecodesign 2009/125/EC
- ▶ **MEPS**

and to buildings:

- ▶ **LEED**
- ▶ **BEAM**
- ▶ **Green Mark**
- ▶ **Green Star**
- ▶ **BREEAM**

RESPONDING TO CLIMATE CHANGE WITH

TRCS2 HFO-Z

New generation chillers with magnetic levitation technology and HFO refrigerant embracing an innovative forward-looking concept of sustainability:



GREEN



The eco-friendly alternative to HFCs

HFO, the new generation low GWP refrigerant

The 4th generation refrigerant HFOs result in being the perfect solution to keep ODP=0 and GWP levels near zero.

HFO 1234ze is a gas blend characterised by extremely low GWP whilst maintaining high efficiency values. Thanks to its compatibility with standard construction materials and operating performance similar to R134a, the new HFO 1234ze is the perfect alternative to HFC refrigerants.

GWP Global Warming Potential

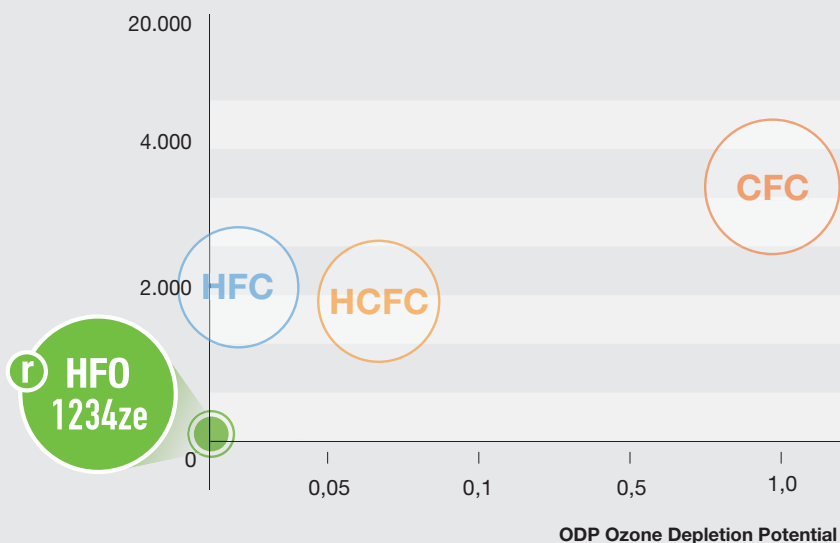

Negligible GWP

HFO 1234ze $GWP_{100 \text{ year}} < 1$
 R134a $GWP_{100 \text{ year}} = 1300$
 (GWP values according to IPCC rev. 5th)

Rapid molecule disintegration in the atmosphere

HFO 1234ze = 2 weeks
 R134a = 14 years

Approved by international standards (ASHRAE 34, ISO 817)

HFO 1234ze classification=A2L (non toxic, mildly flammable), safety group 2 for PED (same as R134a)

Compatible with common construction materials

No special components
 No extra cost

In-line with F-Gas regulation objectives

No future retrofit required



All the advantages of an eco-friendly refrigerant combined with high performing magnetic levitation technology, together with the renowned quality of RC brand solutions. This is TRCS2 HFO-Z's key feature for a long-term sustainable solution that satisfies even the strictest environmental requirements.

EFFICIENCY



The ultimate technology for unbeatable performance

High performance magnetic levitation technology

TRCS2 HFO-Z is the latest technology of chillers with magnetic levitation compressor optimised for HFO 1234ze refrigerant.

The new chiller optimised for HFO is even better performing than its predecessor working with R134a, displaying an increased efficiency value of 3% if considering the same cooling capacity.

Reliability and extended life cycle

Reliability is key in units meant to be forerunners. Thanks to a decade of experience in magnetic levitation compressor units and thousands units installed all over the world, RC brand represents the best proof of total reliability, significant cost savings and longer life cycle (HFO doesn't need any future retrofit due to refrigerant legislation compliance).

Higher efficiency than similar chillers with R134a

TRCS2 HFO-Z EER 3,5	+3,3%
TRCS2-Z EER 3,4	
TRCS2-W HFO-Z EER 5,2	+4%
Traditional water cooled chiller with oil-free compressor EER 5,0	

Less annual energy consumption than similar chillers with R134a

TRCS2 HFO-Z ESEER 5,6	+3,7%
TRCS2-Z ESEER 5,4	
TRCS2-W HFO-Z ESEER 8,2	+3,8%
Traditional water cooled chiller with oil-free compressor ESEER 7,9	

Average values of the series, according to EN14511:2011

TECNOLOGICAL CHOICES

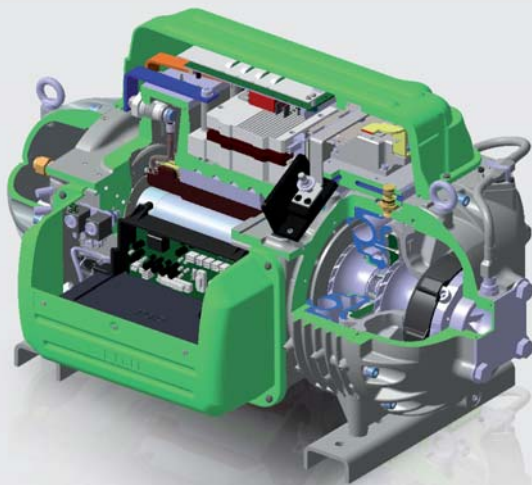

R HF01234ze

MAGNETIC LEVITATION COMPRESSOR SPECIFICALLY DESIGNED FOR HFO

TRCS2 HFO-Z is the result of a smart combination between the centrifugal compressor with magnetic levitation technology and the HFO 1234ze refrigerant. It is well known that the efficiency levels achieved by the magnetic levitation compressors are far superior to those with traditional volumetric compressors.

Besides the reduction of weight and dimensions with respect to traditional compressors, this is a solution that permits the compressor to operate without any oil at all, allowing a significant improvement in the heat exchange performance. Vibrations are virtually eliminated together with possible jolts due to inrush current in the start up phase: the unit's wear is minimised.

The new HFO magnetic levitation compressor is 3% more efficient than similar technology working with R134a.

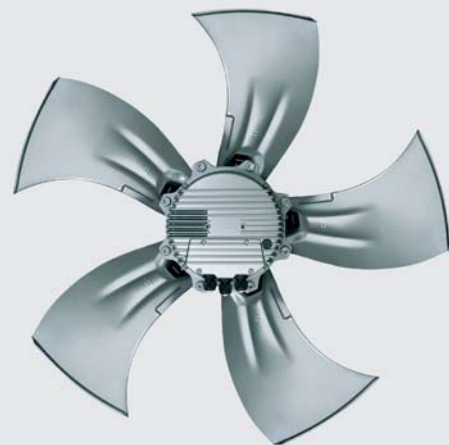

NEW GENERATION EC FANS

EC electronic commutation fans are characterised by high efficiency motor and, according to Regulations 327/2011, their Efficiency Grade is far superior to any other AC fan.

Their extraordinary efficiency, together with really low inrush current, improves chiller performance, especially at partial loads, and contributes to the overall reliability of the unit and thus to relevant running cost savings.

The ability to continuously modulate the rotational speed and perfectly adapt to the plant requirements, provides great advantages in terms of:

- ✓ Minimised sound levels and energy consumption at any load condition
- ✓ Large running cost savings
- ✓ Premium efficiency, especially when all year round operation is required

Efficiency, reliability, silent operation. But also great care of the environmental effects of its components. All of these premises have led to the creation of TRCS2-HFO-Z: the most advanced and eco-compatible solution available on the market.

ADVANCED CONTROLLER

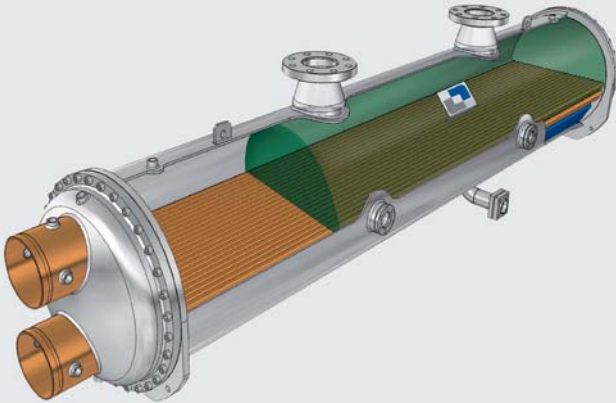

The new controller features proprietary settings which ensure fast adaptive responses to different dynamics. The interface is intuitive and user-friendly thanks to the adoption of LED icons for a full and immediate status display of the various circuits.

As an option, a touch screen interface is available with:

- ✓ 7" color display
- ✓ USB port, for quick and easy application updates and download of all registered variables in graphic form.

INNOVATIVE DESIGN OF THE HEAT EXCHANGERS

The flooded evaporator, fully designed and built internally, together with the shell and tube condenser (in water source units), present an exclusive design aimed at maximising the cooling capacity and optimising the operation of the compressors.

The shell and tube condenser is designed to ensure reduced pressure drops on the water side and to decrease the pumping costs as much as possible. In the evaporator the complete flooding of the tubes is also guaranteed during partial load conditions by an electronic expansion valve, managed by proprietary control logics.

On the evaporator the presence of the refrigerant fluid in the shell side and water in the tube side allows:

- ✓ Minimisation of pressure drops
- ✓ Perfect unified temperature as well as complete refrigerant evaporation
- ✓ No surface for the over-heating
- ✓ Easy cleaning operations

STANDARD INTERFACE

Easy-to read LED icons

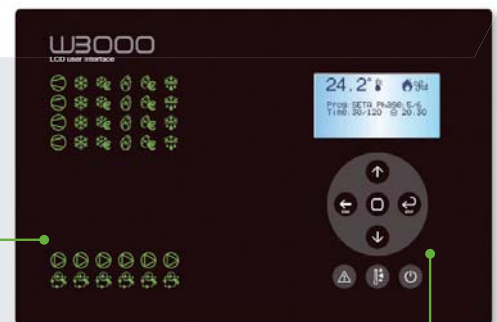

Controls for easy and safe access to the unit's setting

OPTIONAL TOUCH SCREEN INTERFACE

7" colour display



USB port

TRCS2 HFO-Z

0351-1053

HIGH EFFICIENCY AIR COOLED CHILLER FOR OUTDOOR INSTALLATION (339-1017 kW)

Units for outdoor installation, characterised by an extremely compact layout and 4th generation refrigerant HFO 1234ze. TRCS2 HFO-Z units easily adapt to different thermal load conditions thanks to the precise thermoregulation together with the use of inverter technology.



TRCS2 HFO-Z / SL-CA-E			0351	0702	1053
Power supply	V/ph/Hz		400/3/50	400/3/50	400/3/50
PERFORMANCE					
COOLING ONLY (GROSS VALUE)					
Cooling capacity	(1)	kW	339	679	1017
Total power input	(1)	kW	96,3	192	282
EER	(1)	kW/kW	3,52	3,53	3,60
COOLING ONLY (EN14511 VALUE)					
Cooling capacity	(1)(2)	kW	338	677	1014
EER	(1)(2)	kW/kW	3,48	3,50	3,55
Cooling energy class			A	A	A
SEPR HT	(3)(4)		6,97	7,15	6,82
COOLING ONLY 16°C/10°C					
Cooling capacity	(5)	kW	369	737	1109
Total power input	(5)	kW	100	200	293
EER	(5)	kW/kW	3,68	3,68	3,78
COOLING ONLY 23°C/15°C					
Cooling capacity	(6)	kW	427	852	1283
Total power input	(6)	kW	106	214	308
EER	(6)	kW/kW	4,02	3,99	4,17
EXCHANGERS					
HEAT EXCHANGER USER SIDE IN REFRIGERATION					
Water flow	(1)	l/s	16,22	32,45	48,66
Pressure drop	(1)(2)	kPa	27,4	23,1	45,7
REFRIGERANT CIRCUIT					
Compressors nr.		N°	1	2	3
No. Circuits		N°	1	1	2
Refrigerant charge		kg	150	475	550
NOISE LEVEL					
Sound Pressure	(7)	dB(A)	58	59	60
Sound power level in cooling	(8)(9)	dB(A)	90	92	93
SIZE AND WEIGHT					
A	(10)	mm	4000	7900	9700
B	(10)	mm	2260	2260	2260
H	(10)	mm	2430	2430	2430
Operating weight	(10)	kg	3130	6450	7610

Notes:

- Plant (side) cooling exchanger water (in/out) 12°C/7°C; Source (side) heat exchanger air (in) 35°C.
- Values in compliance with EN14511-3:2013.
- Seasonal space heating energy index
- Seasonal energy efficiency of high temperature process cooling [REGULATION (EU) N. 2016/2281]
- Plant (side) cooling exchanger water (in/out) 16°C/ 10°C; Source (side) heat exchanger air (in) 35°C.
- Acqua scambiatore freddo lato utenza (in/out) 23°C/15°C; Aria scambiatore lato sorgente (in) 35°C.
- Average sound pressure level at 10m distance, unit in a free field on a reflective surface; non-binding value calculated from the sound power level.
- Sound power on the basis of measurements made in compliance with ISO 9614.
- Sound power level in cooling, outdoors.
- Unit in standard configuration/execution, without optional accessories.

The units highlighted in this publication contain HFC HFO-1234ze [GWP₁₀₀ 7] fluorinated greenhouse gases.

Certified data in EUROVENT

Accessories:

- ▶ VPF (Variable Primary Flow) kit: variable flow pumps with on board regulation
- ▶ Hydronic group
- ▶ Set-up for remote connectivity with ModBus/Echelon protocol cards

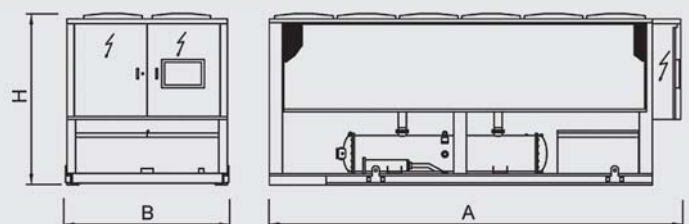

TRCS2-W HFO-Z 0351-1414



HIGH EFFICIENCY WATER COOLED CHILLER FOR INDOOR INSTALLATION (340-1364 kW)

Units for indoor installation, characterised by a minimum footprint and 4th generation refrigerant HFO 1234ze. Conceived to be extremely flexible and reliable units, TRCS2-W HFO-Z are also available with the /H function (heat pump reversible on hydraulic side).



TRCS2-W HFO-Z / HC			0351	0712	1053	1414
Power supply	V/ph/Hz		400/3/50	400/3/50	400/3/50	400/3/50
PERFORMANCE						
COOLING ONLY (GROSS VALUE)						
Cooling capacity	(1)	kW	340	676	1015	1364
Total power input	(1)	kW	63,0	127	190	251
EER	(1)	kW/kW	5,39	5,34	5,35	5,43
COOLING ONLY (EN14511 VALUE)						
Cooling capacity	(1)(2)	kW	339	674	1013	1361
EER	(1)(2)	kW/kW	5,18	5,17	5,19	5,29
Cooling energy class			A	A	A	A
SEPR HT	(3)(4)		9,28	9,27	9,42	9,71
COOLING ONLY 16°C/10°C						
Cooling capacity	(5)	kW	368	734	1102	1477
Total power input	(5)	kW	61,6	124	186	245
EER	(5)	kW/kW	5,98	5,91	5,93	6,03
COOLING ONLY 23°C/15°C						
Cooling capacity	(6)	kW	402	803	1206	1610
Total power input	(6)	kW	56,2	114	170	223
EER	(6)	kW/kW	7,15	7,06	7,09	7,23
EXCHANGERS						
HEAT EXCHANGER USER SIDE IN REFRIGERATION						
Water flow	(1)	l/s	16,24	32,33	48,54	65,22
Pressure drop	(1)(2)	kPa	32,9	29,0	31,1	33,1
HEAT EXCHANGER SOURCE SIDE IN REFRIGERATION						
Water flow	(1)	l/s	19,19	38,25	57,42	76,97
Pressure drop	(1)(2)	kPa	40,8	39,6	32,0	23,0
REFRIGERANT CIRCUIT						
Compressors nr.		N°	1	2	3	4
No. Circuits		N°	1	1	1	1
Refrigerant charge	kg		95,0	230	360	390
NOISE LEVEL						
Sound Pressure	(7)	dB(A)	74	76	77	78
Sound power level in cooling	(8)(9)	dB(A)	92	94	96	97
SIZE AND WEIGHT						
A	(10)	mm	2990	3490	4990	5450
B	(10)	mm	950	1300	1300	1300
H	(10)	mm	1900	1800	1800	1990
Operating weight	(10)	kg	1570	3010	4380	5240

Notes:

- 1 Plant (side) cooling exchanger water (in/out) 12°C/7°C; Source (side) heat exchanger water (in/out) 30°C/35°C.
- 2 Values in compliance with EN14511-3:2013.
- 3 Seasonal space heating energy index
- 4 Seasonal energy efficiency of high temperature process cooling [REGULATION (EU) N. 2016/2281]
- 5 User side heat exchanger water temperature (in/out) 15°C/10°C; source side heat exchanger water temperature (in/out) 30°C/35°C.
- 6 User side heat exchanger water temperature (in/out) 23°C/15°C; source side heat exchanger water temperature (in/out) 30°C/35°C.
- 7 Average sound pressure level at 1m distance, unit in a free field on a reflective surface; non-binding value calculated from the sound power level.
- 8 Sound power on the basis of measurements made in compliance with ISO 9614.
- 9 Sound power level in cooling, indoors.
- 10 Unit in standard configuration/execution, without optional accessories.

The units highlighted in this publication contain HFC HFO-1234ze [GWP₁₀₀ 7] fluorinated greenhouse gases.

Certified data in EUROVENT

Accessories:

- ▶ Integral acoustical enclosure (type base or plus)
- ▶ VPF (Variable Primary Flow) system
- ▶ Several devices for condensation's control
- ▶ Leak detector
- ▶ Set-up for remote connectivity with ModBus/Echelon protocol cards

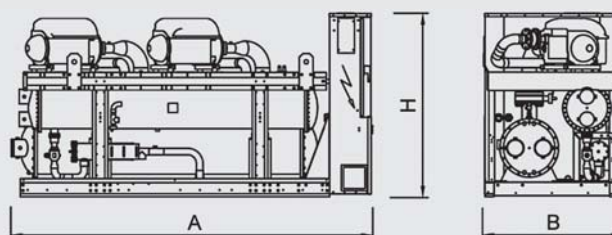

“ BY FAR THE BEST PROOF
IS EXPERIENCE ”

Sir Francis Bacon
British philosopher
(1561 - 1626)

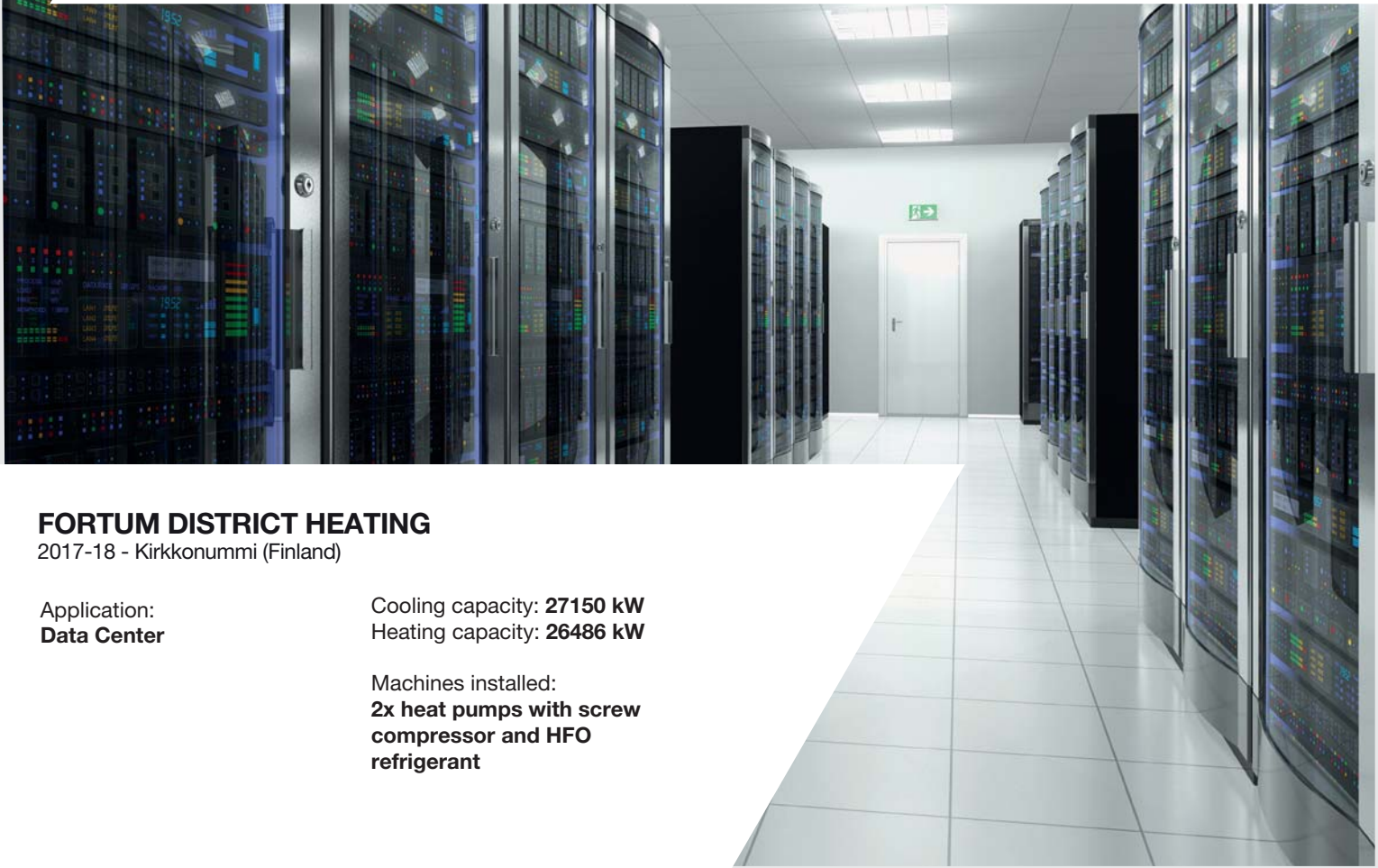

FORTUM DISTRICT HEATING

2017-18 - Kirkkonummi (Finland)

Application:
Data Center

Cooling capacity: **27150 kW**
Heating capacity: **26486 kW**

Machines installed:
**2x heat pumps with screw
compressor and HFO
refrigerant**

PROJECT

Fortum, a Finnish energy company, will utilize the waste heat from a data center and supply the heat into a district heat network in a very innovative and sustainable way. The facility currently generates between 10,000 to 15,000 megawatt-hours of heat waste annually.

CHALLENGE

The heat pumps will be used as a primary cooling method for the data center. Fortum's long-term goal is to serve all the district heating customers in Espoo, Kirkkonummi, and Kauniainen regions with carbon-neutral district heat by 2030 at the latest. Using the heat waste of a data center is a good example of how it is actively possible to move towards low-carbon district heating. Furthermore, as demonstrated in several projects throughout Europe, heat pumps are an energy efficient and economical solution for district heating systems.

SOLUTION

To recover the heat waste of the Ericsson data center and serve the district heating in Kirkkonummi, 2 heat pumps have been supplied through Coromatic, the leading Nordic critical facility solutions provider. The heat pumps have been selected for their efficiency and sustainability as they use HFO-1234ze refrigerant (1,3,3,3-Tetrafluoropropene), which has a minimal greenhouse effect.

Resulting from over 10 year of experience in managing the magnetic levitation technology, the success of TECS2 HFO-Z solutions have been already tested in several renowned projects. Because experience is not only a matter of prestige but also the best proof to provide its customers with the highest quality levels and no-compromise reliability for all kinds of applications.

ASCO TLC DATA CENTRE, TIER III

2016-18 - Treviso - Italy

Application: Data Center
Plant type: HPAC System
Cooling capacity: 861 kW
Installed machines:
 6x Close control chilled water units
 2x air cooled chillers with free cooling and scroll compressors



CNES - CENTRE NATIONAL D'ETUDES SPATIALES

2012 - Saint Denis - France

Application: Data Center
Plant type: HPAC System
Cooling capacity: 432 kW
Installed machines:
 12x Rack Cooler Units
 1x water cooled chiller with screw compressor
 4x Close Control Units



FASTWEB DATACENTER TIER IV

2014 - Milan - Italy

Application: Data Center
Plant type: Hydronic System
Cooling capacity: 2800 kW
Installed machines:
 4x air cooled chillers with turbocor compressors





for a greener tomorrow

Eco Changes is the Mitsubishi Electric Group's environmental statement, and expresses the Group's stance on environmental management. Through a wide range of businesses, we are helping contribute to the realization of a sustainable society.



MITSUBISHI ELECTRIC HYDRONICS & IT COOLING SYSTEMS S.p.A.

Head Office: Via Roma 5 - 27010 Valle Salimbene (PV) - Italy

Tel +39 (0) 382 433 811 - Fax +39 (0) 382 587 148

www.rcitcooling.com

www.melcohit.com